

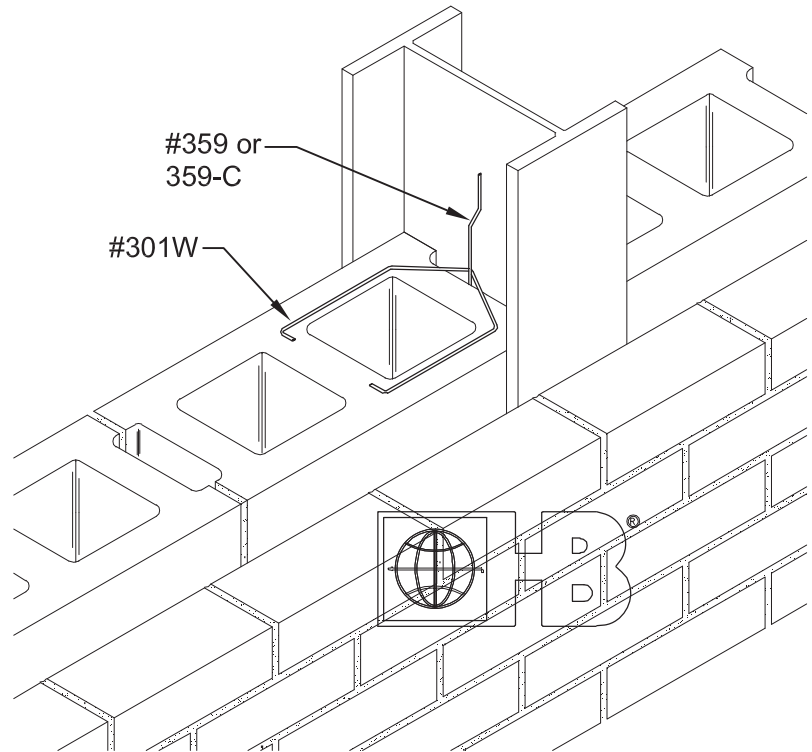

H&B Column and Beam Anchors

04082/HOH
BuyLine 1823

#359 & 359-C - Weld-On Ties

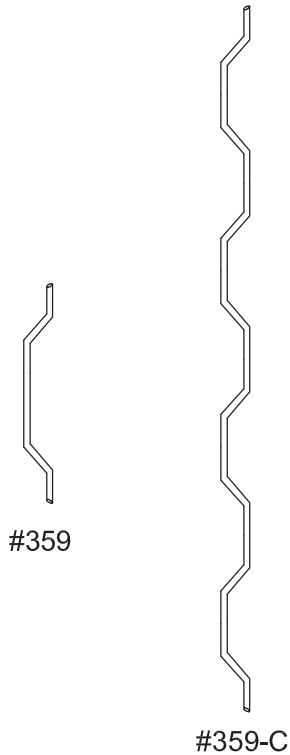

DRAWINGS FOR ILLUSTRATIVE PURPOSES ONLY

<p>WIRE (Carbon Steel): Cold-drawn steel wire conforming to ASTM A 82: Tensile strength - 80,000 p.s.i. Yield Point - 70,000 p.s.i. minimum Zinc Coating: Hot-dip galvanized after fabrication: ASTM A 153 (1.5 oz/ft } Note: Hohmann & Barnard will certify to a minimum of 2.0 oz/ft ²</p> <p>WIRE (Stainless Steel): ASTM A 580 - AISI Type 304 (Type 316 available on special order)</p>	<p>#359: <input type="checkbox"/> 1/4"Ø x 8" long</p> <p>#359-C: <input type="checkbox"/> 1/4"Ø x 8'-0" long with offset @ 8" O.C.</p> <p>FINISHES: <input type="checkbox"/> Plain (No coating) <input type="checkbox"/> Mill galvanized coating: ASTM A 641 (0.1 oz/ft } <input type="checkbox"/> Hot-dip galvanized after fabrication: ASTM A 153 (1.5 oz/ft } <input type="checkbox"/> Stainless Steel: ASTM A 580 - AISI Type 304 (Type 316 available on special order) Note: H&B recommends Stainless Steel for maximum protection against corrosion.</p>
---	---

We Anchor The World



Hohmann & Barnard, Inc.
30 Rasons Court
Hauppauge, New York 11788
TEL: (800) 645-0616 FAX: (631) 234-0683

WEBSITE: www.h-b.com
E-MAIL: weanchor@h-b.com

©HOHMANN & BARNARD, INC. - 1999