

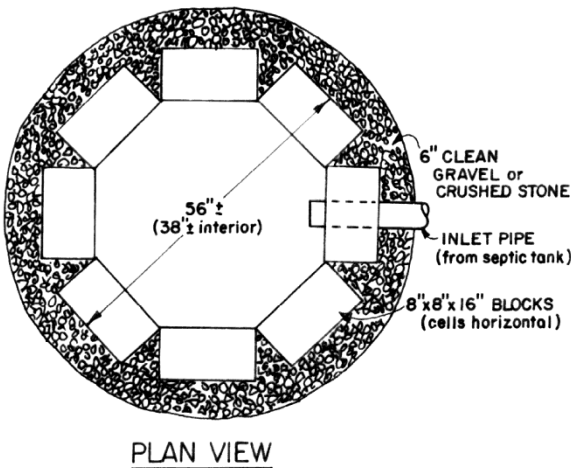

Concrete Block and Precast Concrete Drywell Rings & Covers

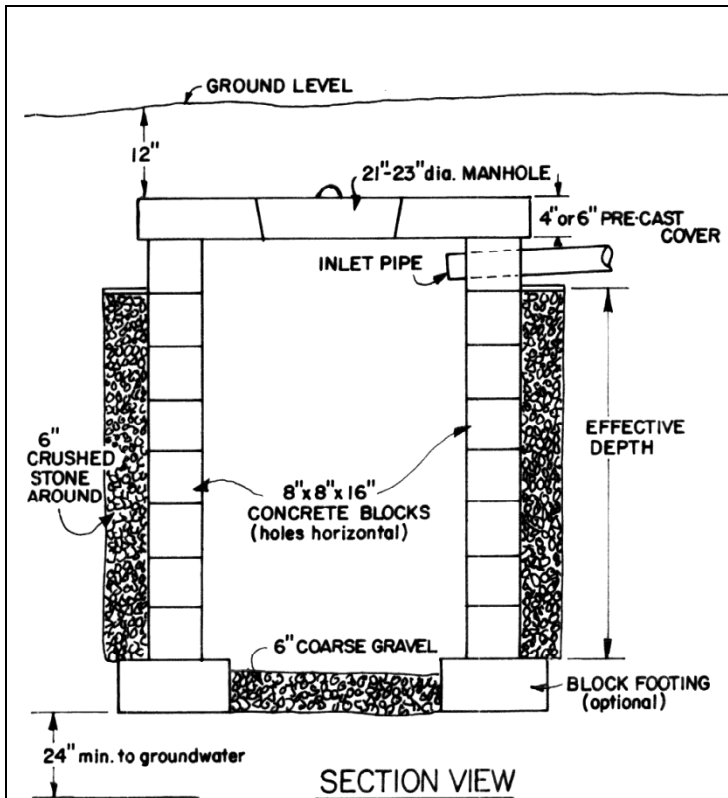

* FOR 80" overall diameter, USE THIRTEEN (13) 8" x 8" x 16" BLOCKS, AS ABOVE SHOWN IN PLAN VIEW; and 84" PRE-CAST COVER

CONCRETE BLOCK DRYWELL

*DRAWINGS ABOVE DETAIL CONSTRUCTION OF DRYWELL COMPATIBLE WITH 60" PRE-CAST COVER

Distributed by:

Manufactured by:

ARNAN DEVELOPMENT CORPORATION
d/b/a **ONEONTA BLOCK COMPANY**
6459 State Highway 23, Oneonta, NY 13820
607-432-6641 • Fax 607-433-6284
www.oneontablock.com

DRAWINGS ON THIS PAGE ARE NOT TO SCALE

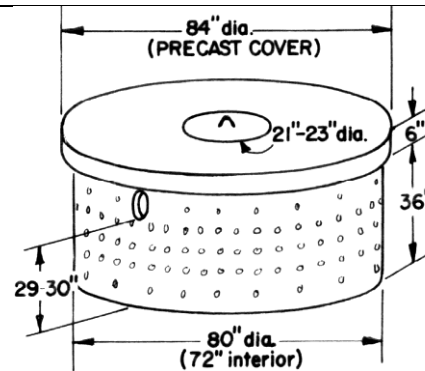

5' Cover
Appx. 1,900 lbs.

8' Cover
Appx. 3,000 lbs.

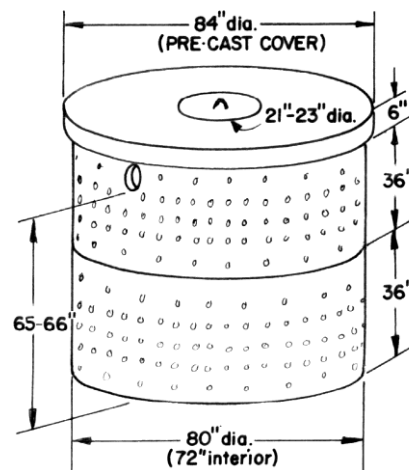

7' Cover, 12" Thick
Appx. 5,200 lbs.

7' Cover
Appx. 2,600 lbs.

5500 Drywell Ring
Appx. 2,200 lbs.

PRE-CAST CONCRETE DRYWELL RINGS & COVERS